

REOWAVE®passive* 480 V / 60 Hz

Electrical and mechanical data

- Insulation class: F
- Climate class: 25/085/21 DIN IEC 68 Part 1
- Ambient temperature: 40° C
- Protection rating: IP00 - The components are supplied as separate components for installation by the customer

Technical data

REOWAVE®passive* 480 V / 60 Hz																					
Image No.	CNW type Choke1/ Choke2	Rated current [A]	Loss [W]	Main choke 1 [mm]					Absorber circuit choke 2 [mm]					Capacitors [mm]						Total weight [kg]	
				L	B1/ B2	H	N1	N2	L	B	H	N1	N2	L	B	H	N1	N2	N3		N4
1/4	8981/9	9	120	190	92	210	170	68	155	77	155	130	57	500	200	100	450	470	100	-	16,2
1/4	8981/12	12	120	190	92	210	170	68	155	92	185	130	72	500	260	230	450	470	100	-	17,5
1/4	8981/16	16	160	230	90	258	176	71	190	82	210	170	58	500	200	100	450	470	100	-	25
2/4	8981/22	22	230	230	114	260	176	95	190	82	210	170	58	500	350	100	450	470	100	125	31,4
2/4	8981/32	32	241	240	117	270	185	95	210	97	238	175	77	500	200	230	450	470	100	125	40,4
2/4	8981/36	36	300	240	132	270	185	109	210	97	238	175	77	500	200	230	450	470	100	125	41,5
1/4	8981/45	45	313	300	120	335	224	94	210	107	238	175	87	500	200	100	450	470	100	-	55,1
3/4	8981/55	55	420	300	152	330	224	119	210	117	238	175	97	500	350	200	450	470	100	125	57,8
3/4	8981/70	70	487	300	165	330	224	132	230	114	260	176	95	500	260	230	450	470	100	-	67,3
3/4	8981/90	90	580	360	193	330	264	167	230	114	263	176	95	500	260	100	450	470	100	-	81,8
3/6	8981/110	110	710	420	189	367	316	159	240	122	280	185	100	500	350	230	450	470	100	125	107,5
3/6	8981/145	145	860	420	204	369	316	174	265	133	270	200	103	500	350	230	450	470	100	125	128

*All variants are also available as REOWAVE®passive Plus

REOWAVE®passive* 480 V / 60 Hz			
Image No.	CNW type Choke1/ Choke2	Rated current [A]	Loss [W]
3/6	8981/800 3/3	800	2510
3/6	8981/1000 3/3	1000	2650
3/6	8981/1200 3/3	1200	3030

A special structure is required for this due to the particular design so
please contact us about this!

Technical data

REOWAVE®passive* 480 V / 60 Hz																						
Image No.	CNW type Choke1/ Choke2	Rated current [A]	Loss [W]	Main Choke1 [mm]					Absorber circuit choke 2 [mm]					Capacitors [mm]						Total weight [kg]		
				L	B1/ B2	H	N1	N2	L	B	H	N1	N2	L	B	H	N1	N2	N3		N4	
3/6	8981/180	180	1000	420	234	368	316	204	300	135	315	224	107	500	260	200	450	470	100	-	157	
3/6	8981/200	200	1100	420	234	369	316	204	300	150	280	224	120	500	260	400	450	470	100	-	165	
3/6	8981/230	230	950	480	220	417	356	184	300	170	280	224	135	500	350	100	450	470	100	125	175	
3/6	8981/270	270	1140	480	250	416	356	214	360	223	310	264	142	500	200	300	450	470	100	-	223	
3/6	8981/330	330	1570	480	250	465	356	214	360	223	310	264	142	500	370	160	450	470	100	125	243	
3/6	8981/370	370	1680	480	250	467	356	214	420	206	364	316	143	500	500	160	450	470	100	275	252	
3/6	8981/400	400	1410	480	250	464	356	214	420	204	363	316	143	500	370	400	450	470	100	125	257	
3/6	8981/450	450	1500	480	250	510	356	214	420	220	363	316	158	500	550	160	450	470	100	275	284	
3/6	8981/550	550	1850	480	250	506	356	214	420	235	364	316	174	500	550	160	450	470	100	275	298	
3/6	8981/650	650	2090	480	250	589	356	214	420	268	363	316	204	500	550	510	450	470	100	275	357	

*All variants are also available as REOWAVE®passive Plus

REOWAVE®passive in IP00

Image 1

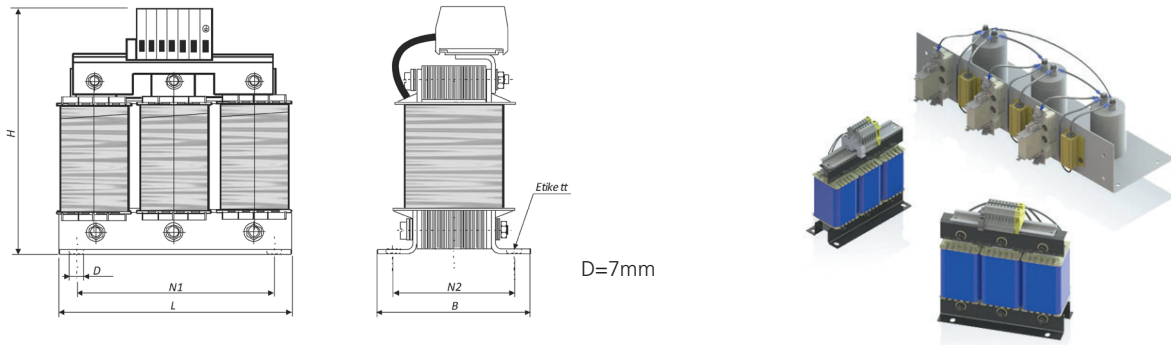

Image 2

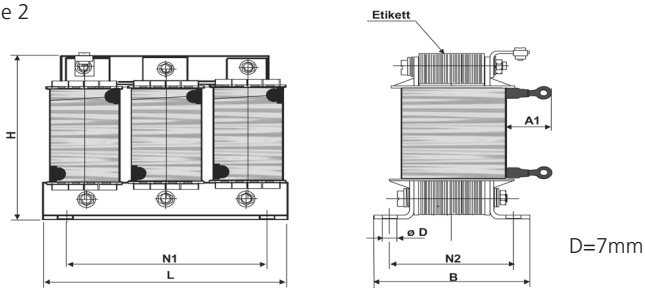
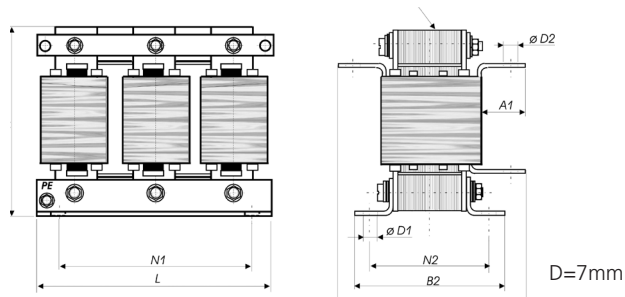
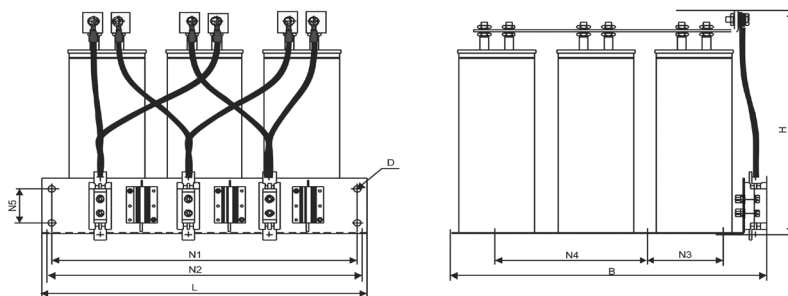

Image 3



Capacitors



REOWAVE®passive in IP20

Image 4

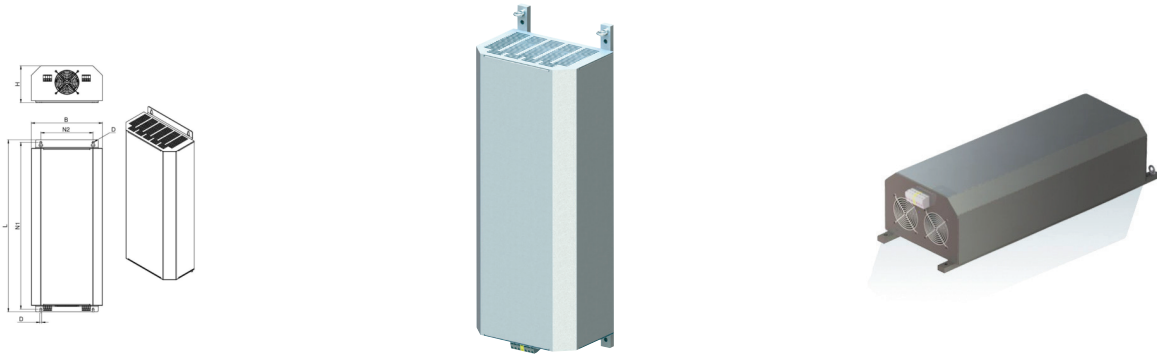

Image 5

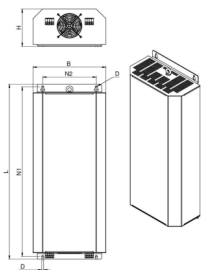

Image 6

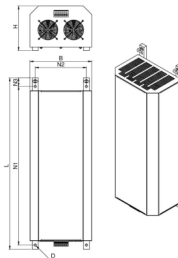

Image 7

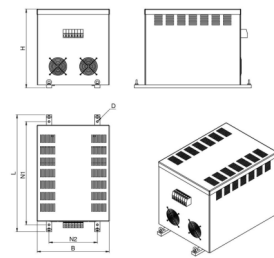

Image 8

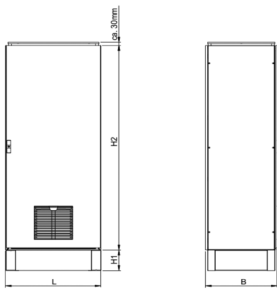

Image 9

